

钳口对机床工作台垂直度 50:0.02，采用优质合金钢制造，表面硬化处理，硬度 HRC58-62，用于数控机床，加工中心及通用机床的铣、镗、钻及磨削。

Perpendicularity of vise jaw and work table is 50:0.02. Made of high quality alloy steel, the case hardness is HRC 58-62. Suitable for milling, boring, drilling and grinding on CNC machine, machining center and ordinary machines.

**SIM.1101**

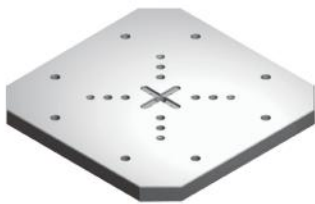

**SIM.1102**



**SIM.1103**



**SIM.1ZC**

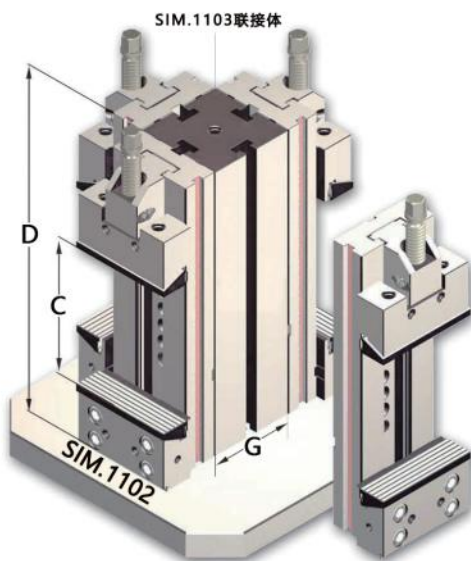

技术参数 TABLE DIMENSION

单位：MM

规格型号	开口度 C	钳体长 D	连接体宽 G	连接体重量 KG
	JAW OPEN	BASE LENGTH	BASE WIDTH	VICE WEIGHT
SIM.1ZC-10010D	100	270	75	12
SIM.1ZC-12515D	150	345	95	25
SIM.1ZC-15020D	200	420	125	50
SIM.1ZC-15030D	300	520		62
SIM.1ZC-17520D	200	455	145	75
SIM.1ZC-17530D	300	555		90
SIM.1ZC-17540D	400	655		105
SIM.1ZC-17550D	500	755		120
SIM.1ZC-20020D	200	495	170	110
SIM.1ZC-20030D	300	595		135
SIM.1ZC-20040D	400	695		160
SIM.1ZC-30030D	300	635	195	190
SIM.1ZC-30040D	400	735		220
SIM.1ZC-30050D	500	835		250

注：SIM.1ZC=4个标准平口钳SIM.1+1个联接体SIM.1103

注：底板SIM.1101&1102为可选配件，可根据工作台尺寸和加工要求特定。